

DESCRIPTION

The Series 4000 Flow Sensor has an in-line, flow-through design using a tangential six bladed impeller.

The Series 4000 Flow Sensor is available in 1/2 in., 3/4 in. and 1 in. pipe sizes and is molded of PVC or PVDF materials. The compact design allows the Series 4000 flow sensor to replace old style magnetic sensors with little or no piping changes.

The proprietary non-magnetic detection circuit is available with two outputs: a low-impedance, 3-wire, 5V DC square wave signal (that can be pulled up to 20V) capable of traveling up to 2000 ft (609 m) without amplification, or a 2-wire, loop-powered, 4...20 mA current analog signal. These two signal formats are compatible with most data acquisition or PLC equipment.

PVDF versions are compatible with all PVDF piping systems including SYGEF, KYNAR, SUPER PROLINE and SANITECH. Adapters are available for use with other plastic or metallic piping systems.

FEATURES

- 4...20 mA analog output programmable in field.
- Enhanced versions can accurately measure flow rates as low as 0.25 fps.
- Flow detection electronics can be serviced or replaced without opening the pipe. No exposure to wetted parts.
- Impeller bearings and shaft can be easily replaced without removing the sensor from the pipe.
- Documented operating service life in high temperature ultra-pure water throughout 40 months of continuous 24 hr/day operation.
- Superior particle-shedding performance verified by independent laboratory testing. Particle sizes from 0.1 micron to 1.0 micron representing "on wafer" metallic contamination (ELYMAT) and liquid-borne particles were monitored.
- CE tested and approved by an independent laboratory.



The analog output is controlled by an on-board microprocessor and digital circuitry producing precise drift free signals. The unit is programmed from a PC using Windows® based software and a connection cable. Units may be pre-programmed at the factory or field programmed. All programming information is stored in non-volatile memory in the sensor.



Mechanical Specifications	Nominal Pipe Size	1/2 in. (20 mm), 3/4 in. (25 mm), 1 in. (32 mm)	
	End Connections	PVC PVDF	Plain end pipe Socket weld/union
	Standard Flow Range	1...20 fps	
	Low Flow Range	0.25...8 fps	
	Accuracy	Better than 1%	
	Repeatability	± 0.5%	
	Max Temp Rating	PVC PVDF	140° F (60° C) 220° F (104° C)
	Max Pressure Rating	PVC PVDF	350 psi @ 73° F (23° C) 275 psi @ 65° F (18° C)
Electrical Specifications	Cable	Digital Output 3-wire Analog Output 2-wire	
	Signal Digital Output	5V CMOS and LSTTL compatible, can be forced up to 20 volts by an external pull-up resistor	
	Analog Output	4...20 mA analog output with offset compensation for ripple less than 0.25% of full scale	
	Sink Current	2...10 mA	
Power	Digital Output	Supply voltage 9...20V DC Supply current 2 mA maximum	
	Analog Output	10...35V DC. Loop power supply voltage and loop series resistance must make sure that the device voltage remains within these limits over the 4...20 mA output span	
	Accessories	840134-0002 USB Converter Model A301-20 programming kit with 20 foot cable	

Архангельск (8182)63-90-72
 Астана +7(7172)727-132
 Астрахань (8512)99-46-04
 Барнаул (3852)73-04-60
 Белгород (4722)40-23-64
 Брянск (4832)59-03-52
 Владивосток (423)249-28-31
 Волгоград (844)278-03-48
 Вологда (8172)26-41-59
 Воронеж (473)204-51-73
 Екатеринбург (343)384-55-89
 Иваново (4932)77-34-06
 Ижевск (3412)26-03-58
 Иркутск (395) 279-98-46

Казань (843)206-01-48
 Калининград (4012)72-03-81
 Калуга (4842)92-23-67
 Кемерово (3842)65-04-62
 Киров (8332)68-02-04
 Краснодар (861)203-40-90
 Красноярск (391)204-63-61
 Курск (4712)77-13-04
 Липецк (4742)52-20-81
 Магнитогорск (3519)55-03-13
 Москва (495)268-04-70
 Мурманск (8152)59-64-93
 Набережные Челны (8552)20-53-41
 Нижний Новгород (831)429-08-12

Новокузнецк (3843)20-46-81
 Новосибирск (383)227-86-73
 Омск (3812)21-46-40
 Орел (4862)44-53-42
 Оренбург (3532)37-68-04
 Пенза (8412)22-31-16
 Пермь (342)205-81-47
 Ростов-на-Дону (863)308-18-15
 Рязань (4912)46-61-64
 Самара (846)206-03-16
 Санкт-Петербург (812)309-46-40
 Саратов (845)249-38-78
 Севастополь (8692)22-31-93
 Симферополь (3652)67-13-56

Смоленск (4812)29-41-54
 Сочи (862)225-72-31
 Ставрополь (8652)20-65-13
 Сургут (3462)77-98-35
 Тверь (4822)63-31-35
 Тюмень (3452)66-21-18
 Ульяновск (8422)24-23-59
 Уфа (347)229-48-12
 Хабаровск (4212)92-98-04
 Челябинск (351)202-03-61
 Череповец (8202)49-02-64
 Ярославль (4852)69-52-93

SERIES 4000 ORDERING MATRIX

		Example	4	0	0	7	10	-	0	0	2	2
Series	4000		4									
Style	Standard Flow			0								
	Enhanced Flow (available with 1/2 in. and 3/4 in. only)			1								
Size	1/2 in.				0							
	3/4 in.				1							
	1 in.				2							
Material	PVC furnished with schedule 80 tail pieces											2
	PVDF socket											3
	PVDF union threaded											4
	PVDF with unions and socket ends											5
	PVDF with 316 stainless steel FNPT union end											7
	PVDF with CPVC socket union end											9
Electronics	Pulse output											00
	Pulse output with EFI foil shield											01
	Pulse output with CE housing											05
	4...20 mA analog output											10
	4...20 mA analog output with EFI foil shield											11
	4...20 mA with CE housing											15
O-Ring (set of 3 rings)	Viton®											0
	EPDM											1
Shaft	Zirconia Ceramic											0
	Hastelloy® C											1
	Tungsten Carbide											2
	316 Stainless Steel											6
	Tantalum											7
Impeller	Tefzel®											2
Bearing	UHMWPE											1
	Tefzel											2
	Teflon®											3

Dimensions

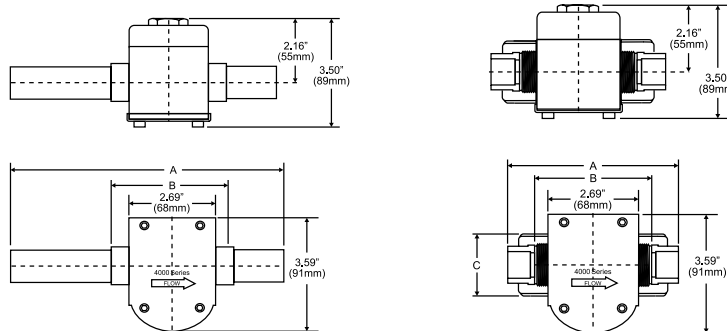

Model	PVC		PVDF			
	A	B	Model	A	B	C
1/2 in.	8.77 in. ± 0.25 in. (222 mm ± 6.35 mm)	4.33 in. (104 mm)	1/2 in.	5.03 in. (128 mm)	3.54 in. (90 mm)	1.85 in. (47 mm)
3/4 in.	10.57 in. ± 0.25 in. (268 mm ± 6.35 mm)	4.69 in. (119 mm)	3/4 in.	5.55 in. (141 mm)	3.92 in. (100 mm)	2.24 in. (57 mm)
1 in.	13.03 in. ± 0.25 in. (331 mm ± 6.35 mm)	5.40 in. (137 mm)	1 in.	6.10 in. (155 mm)	4.32 in. (110 mm)	2.52 in. (64 mm)

Архангельск (8182)63-90-72
 Астана +7(7172)727-132
 Астрахань (8512)99-46-04
 Барнаул (3852)73-04-60
 Белгород (4722)40-23-64
 Брянск (4832)59-03-52
 Владивосток (423)249-28-31
 Волгоград (844)278-03-48
 Вологда (8172)26-41-59
 Воронеж (473)204-51-73
 Екатеринбург (343)384-55-89
 Иваново (4932)77-34-06
 Ижевск (3412)26-03-58
 Иркутск (395) 279-98-46

Казань (843)206-01-48
 Калининград (4012)72-03-81
 Калуга (4842)92-23-67
 Кемерово (3842)65-04-62
 Киров (8332)68-02-04
 Краснодар (861)203-40-90
 Красноярск (391)204-63-61
 Курск (4712)77-13-04
 Липецк (4742)52-20-81
 Магнитогорск (3519)55-03-13
 Москва (495)268-04-70
 Мурманск (8152)59-64-93
 Набережные Челны (8552)20-53-41
 Нижний Новгород (831)429-08-12

Новокузнецк (3843)20-46-81
 Новосибирск (383)227-86-73
 Омск (3812)21-46-40
 Орел (4862)44-53-42
 Оренбург (3532)37-68-04
 Пенза (8412)22-31-16
 Пермь (342)205-81-47
 Ростов-на-Дону (863)308-18-15
 Рязань (4912)46-61-64
 Самара (846)206-03-16
 Санкт-Петербург (812)309-46-40
 Саратов (845)249-38-78
 Севастополь (8692)22-31-93
 Симферополь (3652)67-13-56

Смоленск (4812)29-41-54
 Сочи (862)225-72-31
 Ставрополь (8652)20-65-13
 Сургут (3462)77-98-35
 Тверь (4822)63-31-35
 Томск (3822)98-41-53
 Тула (4872)74-02-29
 Тюмень (3452)66-21-18
 Ульяновск (8422)24-23-59
 Уфа (347)229-48-12
 Хабаровск (4212)92-98-04
 Челябинск (351)202-03-61
 Череповец (8202)49-02-64
 Ярославль (4852)69-52-93