



Ellipse® Pitot Tube Meter

AF Annular Flanged

DESCRIPTION

The Preso ELLIPSE® Model: AF (Annular Flanged) is a multi-ported, self averaging differential pressure flow element.

CONFIGURATION

The flow element has a two piece construction, of an elliptical shape with two 100% independent flow sensing chambers to prevent signal degradation and mixing or that require dampening hardware or software. The impact velocity sensing holes are located along the leading edge and the true static sensing holes are on the exterior probe side. The probe does not generate any vortices or vacuum effects that impinge on the static pressure measurement sensing area and has a drag coefficient of 0.32 or less. Each flow sensor is complete with instrument shut off valves with provisions to accept a transmitter or direct indicating meter. An identification tag is supplied with specific flow station measurement information as required.

MATERIALS

All sensing elements are 316/316L stainless steel. The mounting coupling and flange are the same material as the process pipe material. The station is rated according to ANSI flange standards and is selected to meet actual design conditions

ACCURACY & REPEATABILITY

The accuracy of the flow element is within $\pm 0.75\%$ with a repeatability of $\pm 0.1\%$ and turndown of 17:1 in the corresponding and appropriate range of Reynolds' Numbers. Certified, independent test data is available from NIST laboratories in similar line sizes as well as in liquids and gases.

QUALITY

All flow sensors are manufactured under an ISO 9001:2008 certified quality program. Certification documentation is available for inspection. To prevent corrosion, no welds, rough surfaces or longitudinal depressions are part of the sensor in the fluid stream.

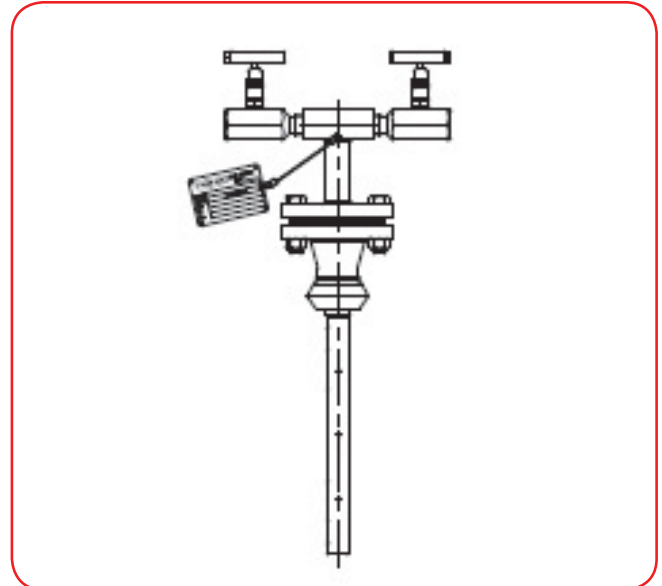

APPLICABLE FLUIDS

Liquids and gases.

COMPONENTS

All sensors are furnished with 1/2" instrument valves, flanged mounting hardware (with the proper ratings), and ID tag as standard equipment. Available options include: Integral 3-valve or 5-valve transmitter mount manifold and integral RTD temperature sensor.

По вопросам продаж и поддержки обращайтесь:

Архангельск (8182)63-90-72
Астана +7(7172)727-132
Астрахань (8512)99-46-04
Барнаул (3852)73-04-60
Белгород (4722)40-23-64
Брянск (4832)59-03-52
Владивосток (423)249-28-31
Волгоград (844)278-03-48
Вологда (8172)26-41-59
Воронеж (473)204-51-73
Екатеринбург (343)384-55-89
Иваново (4932)77-34-06
Ижевск (3412)26-03-58
Иркутск (395) 279-98-46

Казань (843)206-01-48
Калининград (4012)72-03-81
Калуга (4842)92-23-67
Кемерово (3842)65-04-62
Киров (8332)68-02-04
Краснодар (861)203-40-90
Красноярск (391)204-63-61
Курск (4712)77-13-04
Липецк (4742)52-20-81
Магнитогорск (3519)55-03-13
Москва (495)268-04-70
Мурманск (8152)59-64-93
Набережные Челны (8552)20-53-41
Нижегород (831)429-08-12

Новокузнецк (3843)20-46-81
Новосибирск (383)227-86-73
Омск (3812)21-46-40
Орел (4862)44-53-42
Оренбург (3532)37-68-04
Пенза (8412)22-31-16
Пермь (342)205-81-47
Ростов-на-Дону (863)308-18-15
Рязань (4912)46-61-64
Самара (846)206-03-16
Санкт-Петербург (812)309-46-40
Саратов (845)249-38-78
Севастополь (8692)22-31-93
Симферополь (3652)67-13-56

Смоленск (4812)29-41-54
Сочи (862)225-72-31
Ставрополь (8652)20-65-13
Сургут (3462)77-98-35
Тверь (4822)63-31-35
Томск (3822)98-41-53
Тула (4872)74-02-29
Тюмень (3452)66-21-18
Ульяновск (8422)24-23-59
Уфа (347)229-48-12
Хабаровск (4212)92-98-04
Челябинск (351)202-03-61
Череповец (8202)49-02-64
Ярославль (4852)69-52-93

Киргизия (996)312-96-26-47

Казахстан (772)734-952-31

Таджикистан (992)427-82-92-69

Эл. почта bdg@nt-rt.ru || Сайт: <http://badger.nt-rt.ru>